

REV	DESCRIPTION	ECN #	CHG BY	DATE	APP'D
A	UPD TITLE BLOCK, ADD METRIC SPECS, CHNGD HT	-	DDH	06/10/15	CRW
B	UPDATED TO 3D	16670	NAD	07/16/19	TAS

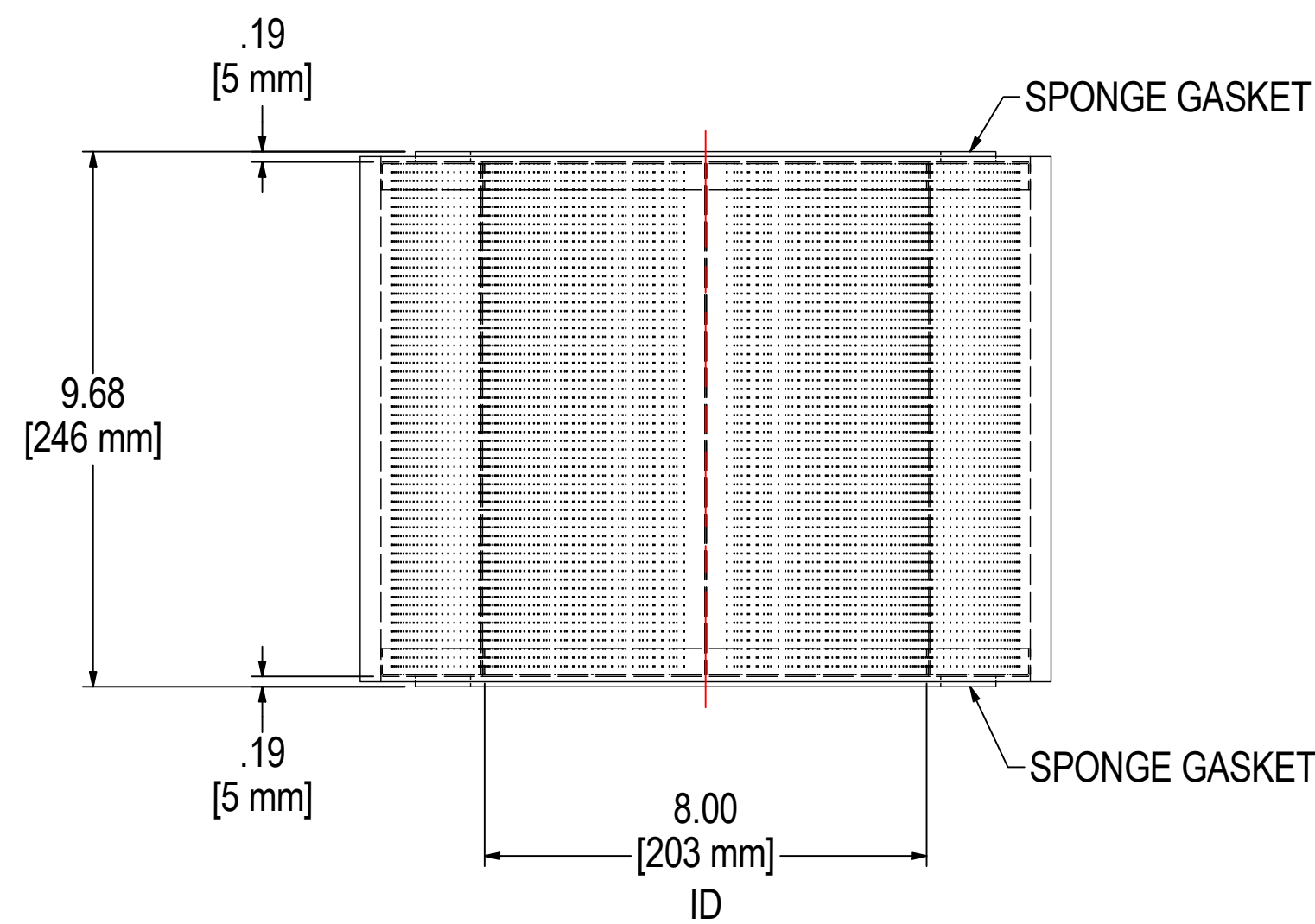
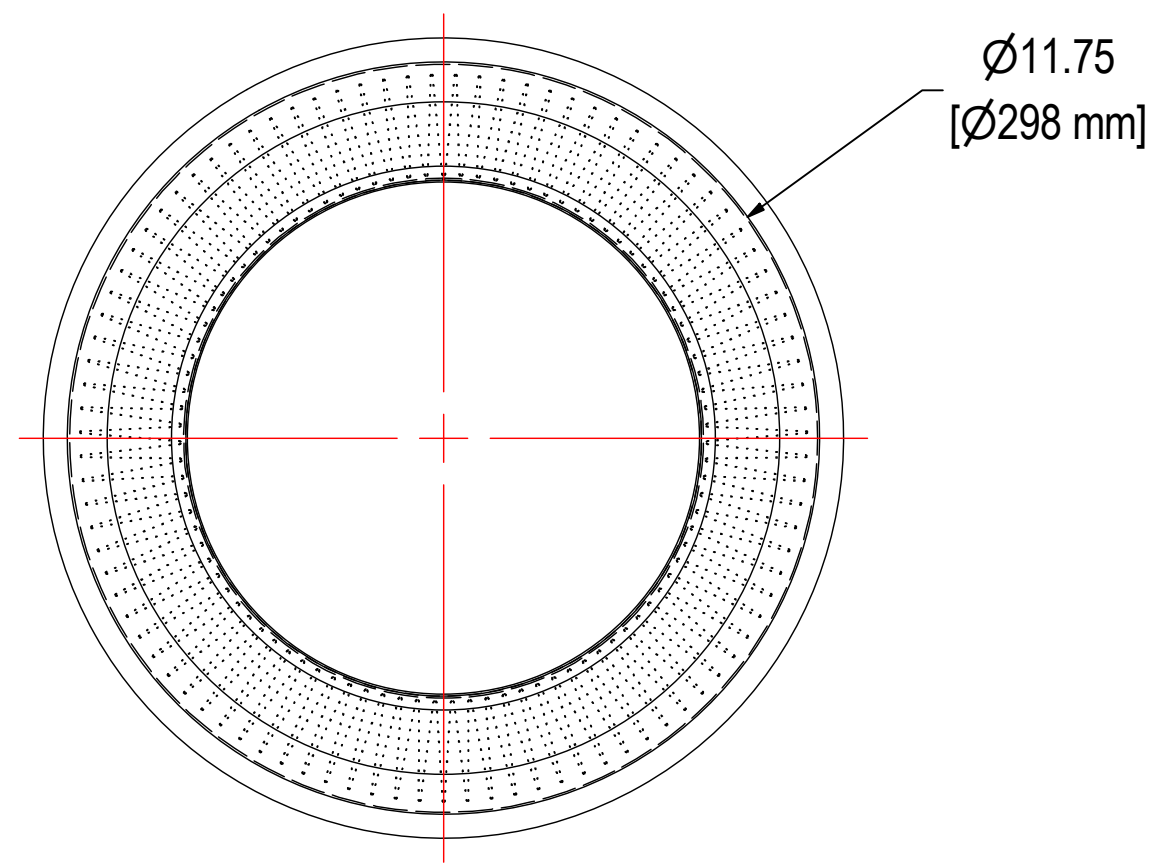

ELEMENT SPECS		
PART NUMBER	275P	
MATERIAL	POLYESTER	
FLOW RATE	1100 CFM	1869 m ³ /hr
SURFACE AREA	19.8 ft ²	1.8 m ²
I.D.	8.00"	203mm
O.D.	11.75"	298mm
HEIGHT	9.32"	237mm